

High Accuracy 10k NTC Thermistors (Single Elements)

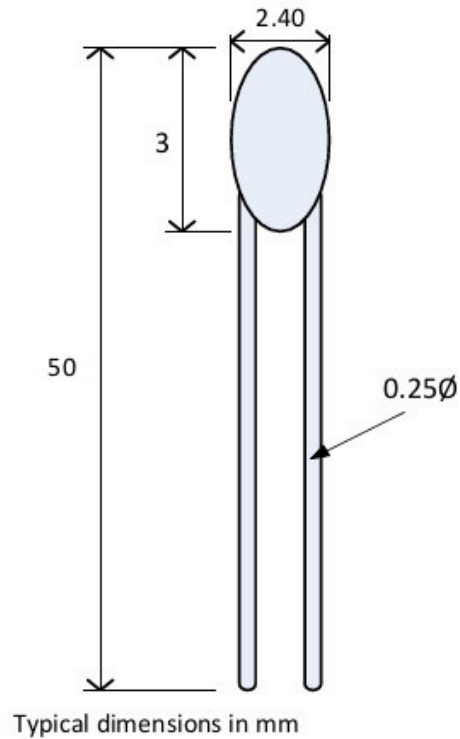

Labfacility are the UK's leading manufacturer of Temperature Sensors, Thermocouple Connectors and associated Temperature Instrumentation and stockings of Thermocouple Cables. The Company has been trading since 1971 and is ISO9001 accredited.

High Accuracy 10k NTC Thermistors (Single Elements)

a range of interchangeable, epoxy coated bead NTC thermistors. These RT curve matched thermistors have become industry standards.

They are ideal for the applications listed below due to their fast thermal response time and high accuracy, typically $\pm 0.2\text{K}$ over 0 to 70°C.

Applications

Home Automation / IOT Devices

Industrial electronics / instrumentation

Automotive electronics

Medical applications

Features

Fast response design

Standard accuracy $\pm 0.2\text{K}$ (over 0-70°C)

Interchangeable between NTC's

Excellent long-term stability

Operating range -50°C to 150°C

Temperature coefficient at 25°C

P25

$\geq 4\%/^{\circ}\text{C}$

Reference Temperature

T_n

25°C

Dissipation factor (in air)

?th

Approx. 1.5mW/K

Thermal time constant (in air)

T_c

Approx. 10s

Specifications

Specifications

Product Code	XE-9900-001
Thermistor	10K NTC Thermistor
BETA 25/85	3977K
Max. Temperature	150°C
Min. Temperature	-50°C
Accuracy	+/- 0.2K (over 0-70°C)